

**INSTRUCTION
MANUAL**

B+K PRECISION 467

CATHODE RAY TUBE RESTORER/ANALYZER



B+K PRECISION

Product of DYNASCAN CORPORATION
6460 West Cortland Street, Chicago, Illinois 60635



Dear Friend:

Congratulations on your purchase of B & K-Precision Test Equipment, and welcome to the B & K-Precision family. We hope your experience with your new test equipment will make you a lifetime B & K-Precision customer.

Your instrument is backed by more than 20 years of experience in designing and manufacturing. Our most important goal is your satisfaction. At B & K-Precision, test equipment is made to meet the demands of the field, focusing on dependability and accuracy. We also concentrate on simplicity and operating ease with features that reduce the possibility of human error and speed the servicing process.

In order to determine the type of test units that are needed we have been guided by letters and reports from technicians and engineers who use the equipment daily. Our field tests and studies have helped provide better and faster service techniques.

B & K-Precision product designs are constantly reviewed, and refinements are made or new models developed to meet advances in our industry and to fill your needs. We set our standards high so you can be assured that B & K-Precision test instruments you buy represent advanced design, quality construction, and dependable long-term performance at a price you can afford.

If you have any comments or thoughts about our products, or test equipment in general, I would be delighted to hear from you.

Thanks for your confidence in B & K-Precision and we look forward to serving you for a long time to come.

Sincerely,

Carl Korn
President

INSTRUCTION MANUAL

FOR

MODEL 467

CATHODE RAY TUBE
RESTORER/ANALYZER



DYNASCAN CORPORATION
6460 West Cortland Street
Chicago, Illinois 60635

TABLE OF CONTENTS

	Page
INTRODUCTION AND SPECIAL FEATURES	3
SPECIFICATIONS	4
SAFETY PRECAUTIONS	5
BRIEF SUMMARY OF WHAT THE 467 WILL DO	5
CONTROLS AND INDICATORS	6
USING THE MODEL 467	9
Operation	9
Restoring the Picture Tube	13
Cleaning, Balancing and Rejuvenating	14
HOW THE MODEL 467 WORKS	16
Emission Test	16
Tracking Test	16
Leakage Test	16
Life Test	20
Focus Test	20
Shorts Removal	22
Cathode Restoring	23
FIELD CALIBRATION	25
SET-UP CHARTS	26
WARRANTY INSTRUCTIONS	27
WARRANTY	28

INTRODUCTION

THE MODEL 467 USES UNIQUE TRIDYNAMIC® APPROACH

The Model 467 CRT Restorer/Analyzer has been designed by B & K to evaluate any television picture tube with a high degree of accuracy. This professional quality CRT tester utilizes solid state digital multiplexing circuits which provide new testing capabilities. This unique TriDynamic® approach to CRT testing makes it possible to test all types of CRT's – even Trinitrons and in-line types – by using just one simple test procedure.

SPECIAL FEATURES

Each test function has been designed to provide more rapid testing, in addition to reducing human error. These features include:

1. A control panel which guides the user easily through the correct test sequence.
2. Three precision meters that display emission from all 3 guns simultaneously, to minimize testing time.
3. Simultaneous leakage measurements between all important elements. No controls to adjust. Even cathode-to-cathode leakage can be detected.
4. Heater voltage, G1 voltage, and line voltage are precisely and simultaneously indicated on the three meters.
5. Continuously variable heater voltage, which can be precisely set on the meter. All common CRT heater voltages are premarked on the meter scale. The voltages to G1 and G2 are continuously variable, permitting the tube to be checked under conditions simulating its actual use in the receiver.
6. New color tracking feature which greatly reduces time required for determining proper color gun tracking.
7. A new, greatly improved rejuvenation capability is provided for each gun independently. The entire process is automatically timed and operated by simply depressing the RESTORE button. The rejuvenate feature provides maximum cathode restoration while at the same time minimizing the possibility of cathode destruction.
8. Simplified automatic life test.
9. Function switching between rejuvenation and emission test permits instant evaluation of restoration effectiveness.
10. New, improved, more versatile adapter set is included. It provides capability to directly test more CRT types *with fewer adapters* than any other currently available tester.
11. Continuity to focus electrodes is quickly checked by the simple push of a button.
12. Short indicator lamp shows instantly when G1-K short has been successfully removed.

SPECIFICATIONS

TYPES OF CRT'S TESTED: All black and white and color TV picture tubes.

TESTS PERFORMED:

- Emission
- Leakage
- Tracking (Color Tubes)
- Life
- Focus Continuity

RESTORING FUNCTIONS:

- Shorts Removal
- Gun Cleaning and Balancing
- Cathode Rejuvenation

METERS: (Three; 2½"; D'Arsonval movement.)

Meter Indications:

- Emission (0-2mA)
- Restoring Current (0-2 scale)
- Heater Voltage (0-15V)
- G1 Bias Voltage (30-100V)
- Power Line Voltage (100-130V)

TEST VOLTAGES:

- Heater: 0 - 7 @ 2.0A
7 - 14 @ 600 mA
- G1 Bias: Neg. 30 to Neg. 100 VDC
- G2 Supply: Normal, 0-350 VDC
High, 180-530 VDC

ACCESSORIES:

- CRT Socket Adapters: 6 supplied; optional adapters available for all common TV picture tubes.
- Set-up Chart: Shows adapter number and test voltages.

POWER REQUIREMENTS: 117 VAC, 60 Hz, 40 Watts.

FUSES (INTERNAL): Heater Supply - Type 3AG, 0.3A Slo-B1o
High Voltage Supply - Type 3AG, 3/8A Slo-B1o

CASE: One-piece, high-impact polyethylene, with internal cord and adapter storage.

SIZE: 13½" x 10" x 5¾".

WEIGHT: 10 lbs.

SAFETY PRECAUTIONS

1. The proper power line supply voltage is indicated on the chassis where the power cord enters the instrument. Do not attempt to operate this instrument from a power source other than specified.
2. When testing any CRT that is installed in a chassis, first disconnect the chassis power plug from the AC line outlet. **DO NOT APPLY POWER TO THE TV CHASSIS AT ANY TIME DURING THE TEST OF A CRT.**

BRIEF SUMMARY OF WHAT THE 467 WILL DO

The Model 467 CRT Restorer/Analyzer will:

1. Rapidly test a cathode ray tube for satisfactory emission.
2. Restore tubes having low emission.
3. Check for shorts or leakage between the elements in the tube, and also indicate between which elements the fault exists.
4. Check relative cathode emission, to directly and rapidly indicate balance (tracking) between the guns of a color CRT.
5. Check the life expectancy of the tube.
6. Repair the most common shorts in cathode ray tubes: those between cathode and G1.
7. Check continuity to the focus electrode of the gun(s).

CONTROLS AND INDICATORS

- | | |
|--|---|
| 1. Function Switch: | Selects Main Functions.
POWER OFF
SET-UP
SET CUTOFF
TEST EMISSION
RESTORE |
| 2. G2 Voltage Range Switch:

NORMAL position
HIGH position | Selects two ranges of G2 supply voltage.
0 – 350 VDC
180 – 530 VDC |
| 3. HTR RANGE Switch:
0 – 4 position
4 – 7 position
7 – 9 position
8 – 11 position
10 – 12 position
12 – 14 position | Coarse adjustment of heater voltage.
0 – 4 VAC @ 2.0A
4 – 7 VAC @ 2.0A
7 – 9 VAC @ 0.6A
8 – 11 VAC @ 0.6A
10 – 12 VAC @ 0.6A
12 – 14 VAC @ 0.6A |
| 4. SET HEATER Control: | Fine adjustment of heater voltage
± 2 VAC. |
| 5. RED/B&W meter: | Reads emission of red gun or black and white tube. Reads heater voltage when FUNCTION SWITCH (1) is in SET-UP position. |
| 6. SET G1 Control: | Adjusts control grid bias voltage when FUNCTION SWITCH (1) is in SET-UP position. |
| 7. GREEN Meter: | Reads emission of green gun. Reads value of G1 bias voltage when function switch is in SET-UP position. |
| 8. BLUE Meter: | Reads emission of blue gun. Reads power line voltage when FUNCTION SWITCH (1) is in SET-UP position. |

- | | |
|--|---|
| <p>9. LEAKAGE Lamps:</p> | <p>Indicates leakage from cathodes to heater or G1 and between cathodes when FUNCTION SWITCH (1) is in SET-UP position.</p> |
| <p>10. G2 Control – RED
11. G2 Control – GREEN
12. G2 Control – BLUE</p> | <p>Adjusts value of G2 voltage to SET CUTOFF condition of test.</p> |
| <p>13. TRACKING Pushbutton:

 TRACKING Control:</p> | <p>Activates tracking adjustment control.
Simultaneously varies readings of the three emission meters (5, 7, 8,) from 10% to 90%.</p> |
| <p>14. LIFE Test Pushbutton:</p> | <p>Automatically reduces heater voltage by 15% from the value set on meter (5) -</p> |
| <p>15. FOCUS Test Pushbutton:

 FOCUS OK Lamp:</p> | <p>Activates focus electrode continuity test.
Indicates continuity from CRT base pin to focus electrode.</p> |
| <p>16. REMOVE SHORTS Pushbutton:

 G1-K SHORTS Lamp:</p> | <p>Discharges capacitor through short between G1 and cathode.
Indicates presence of short circuit between G1 and cathode.</p> |
| <p>17. REJUVENATE/CLEAN•BALANCE Selector Switch:</p> | <p>Selects value of high voltage to be used for REJUVENATE or CLEAN•BALANCE operation.</p> |
| <p>18. }
19. } RESTORE Pushbuttons:
20. }</p> | <p>Applies restoring voltage between G1 and cathode, and simultaneously interrupts heater voltage.</p> |
| <p>21. RESTORE Ballast Lamp:</p> | <p>Indicates restoring current in ballast lamps.</p> |
| <p>22. POWER Lamp:</p> | <p>Indicates power is "on".</p> |

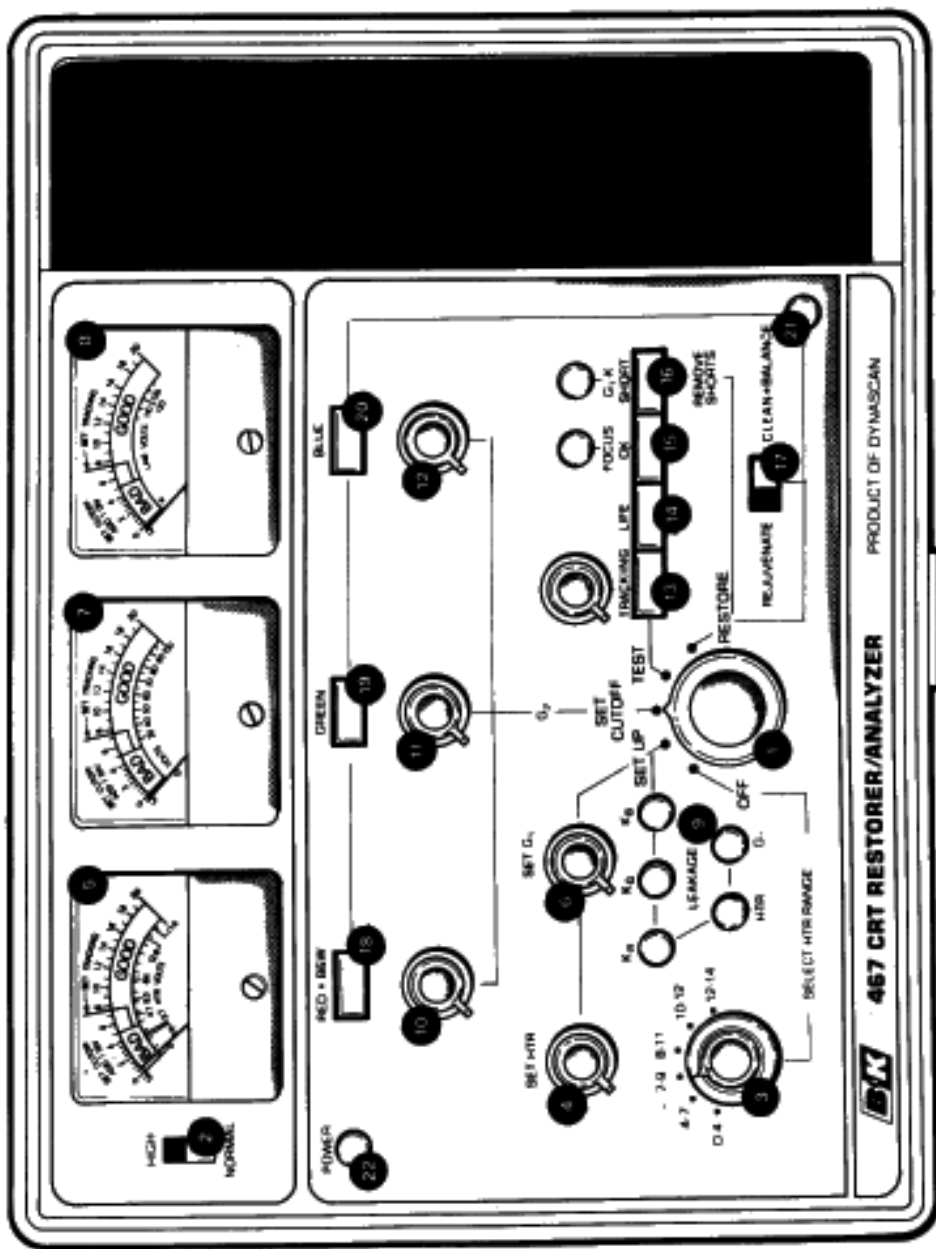

CONTROL PANEL OF MODEL 467

USING THE MODEL 467

INTRODUCTION

The following procedure describes in detail the use of the 467. In addition, comments and notes are provided regarding the significance of the readings to aid the user in interpreting the measurements obtained.

Because of the unique design of this instrument, all tube types are tested in the same manner regardless of gun structures. After the user has become thoroughly familiar with the instructions and the instrument itself, he will need only to refer to the SET-UP CHART booklet.

HOW TO USE THE SET-UP CHARTS

For convenience, color and black/white CRT's are grouped separately. In each group the tubes are listed first in increasing numerical order by screen size, whether in inches or millimeters; then in alphabetical order, by the letters following the screen size.

Foreign tubes having alphabetical prefixes are listed at the end of the listing of tube types having numerical prefix identification.

OPERATION

(Refer to Control Panel Illustration)

A. SET-UP:

1. Set FUNCTION Switch (1) to the OFF position.
2. Plug the Model 467 line cord into a convenient power outlet.
3. Set all variable controls fully counterclockwise.
4. Locate the type number of the CRT to be tested in the SET-UP CHART.
5. Select the adapter by the number indicated and connect it to the adapter cable.
6. Place the G2 NORM/HIGH (2) in the NORM position.
7. Set the HTR RANGE Switch (3) to the range which includes the heater voltage shown in the SET-UP CHART.
8. If the CRT to be tested is mounted in the TV set, *make sure that power to the TV set is removed*, preferably by unplugging the set. A shock hazard and possibility of damage to the 467 exists if an attempt is made to test the CRT with the TV set operating.
9. Connect the socket adapter to the base of the CRT, taking care to align keyway properly.
10. Rotate the function switch to SET-UP position.

11. Carefully adjust the SET HTR control (4) while observing the HTR VOLTS scale of the RED/B&W meter (5) for the heater voltage indicated in the SET-UP CHART. For convenience, the most common heater voltages are precisely marked.
12. Adjust the SET G1 control (6) while observing the G1 VOLTS scale of the GREEN meter (7) until the meter indicates the value of G1 specified in the SET-UP CHART. (50V unless indicated by*.)
13. The LINE VOLTS scale on the BLUE meter (8) automatically monitors line voltage present at the time of the test while the FUNCTION switch is in the SET-UP position. This may be helpful in diagnosing some symptoms related to low line voltage. For example, a marginal picture tube might perform very poorly with low line voltage because of the reduced heater voltage.

B. LEAKAGE TEST:

With the FUNCTION switch in the SET-UP position, observe the five LEAKAGE lamps (9). When glowing, these lamps automatically indicate leakages between cathodes, or from any cathode to the heater or to G1. For example, if the KB, KR, and G1 lamps glow, it is an indication of leakage between the blue cathode, the red cathode, and the control grid. Only those elements which have leakage between them, in the order of 2 megohms or less, will be indicated by the lamps glowing.

NOTE

If the leakage lamps glow very faintly, even though the CRT tests normal in all other functions, the cause may be dirt or other contamination between the tube base pins. This can usually be ignored.

Heater-Cathode Leakage: Leakage between heater and cathode cannot be repaired. When such leakage is determined to be the cause of set malfunction, it is necessary to replace the picture tube. If the TV heater power source permits the use of an isolating transformer, its use may restore normal operation.

Cathode-to-Cathode Leakage: Excessive leakage between cathodes can sometimes result in TV set malfunction. Such leakage cannot be repaired.

Grid-to-Cathode Leakage: Excessive leakage or a short between the control grid and cathode is a common fault in picture tubes. Any current path below two megohms will light the G1-K LEAKAGE lamp (16). Shorts and leakage paths below 20k ohms will *also* light the G1-K SHORTS lamp when the function switch is in the RESTORE position. If only leakage is indicated, restore the tube by using the CLEAN•BALANCE procedure; if a G1-K short exists, use the REMOVE-SHORTS procedure (see "RESTORING THE PICTURE TUBE").

C. SET CUT-OFF:

1. Rotate the FUNCTION Switch to the SET CUT-OFF position. The 3 meters should read zero or slightly above or below zero.
2. Slowly advance each of the three G2 controls (10), (11), and (12) clockwise until the corresponding meter rises one small division of the meter scale. This adjustment sets the G2 voltage at the value for spot cut-off of each color gun. If a tube or gun cannot be brought out of cut-off by advancing the G2 control fully clockwise, place the G2 NORM/HIGH switch (2) in the HIGH position.

NOTE

For black and white tubes, use only the RED G2 control. Make sure the others are turned fully counterclockwise.

D. EMISSION TEST:

Rotate the FUNCTION Switch to the TEST position. The three meters will indicate the cathode emission current for each of the three electron guns. In some instances, the meters may read somewhat beyond the full scale deflection. This indicates that the tube has excellent emission. A greater than full scale reading will not in any way damage the instrument. In some cases, the current may rise to approximately $\frac{1}{2}$ or $\frac{3}{4}$ scale and then slowly decrease. Evaluation of emission should be made when the readings have stabilized. In all cases, if the emission readings stay well within the green (GOOD) area, the emission characteristics of the tube may be considered acceptable. If emission reads in the red (BAD) area, proceed to REJUVENATE (see "RESTORING THE PICTURE TUBE").

E. TRACKING TEST:

1. With the FUNCTION Switch in the TEST position, depress and hold the TRACKING pushbutton (13).
2. With TRACKING button depressed, rotate the TRACKING knob (13) so that the pointer of the highest reading meter coincides with the SET TRACKING LINE located at the high end of the yellow wedge on the meter scale.
3. Observe the other two meters and note if the readings are within the yellow tracking wedges on each meter. If all three pointers are within the yellow wedges, the tracking ratio of the CRT is acceptable. If the tube does not track, proceed to CLEAN-BALANCE (see "RESTORING THE PICTURE TUBE").
4. When the TRACKING button is released, the three meters immediately will return to the original emission readings that were obtained in the emission test. The tracking pushbutton may be depressed as often as desired without affecting the calibration of the emission readings.

F. LIFE TEST:

1. With the FUNCTION Switch in the TEST position, depress and hold the LIFE pushbutton (14) and allow the emission readings to stabilize. For acceptable long term CRT performance, the readings should stay in the green (GOOD) area. The less the emission drops, the longer the life expectancy of the tube.
2. While holding down the LIFE button, depress the TRACKING button and perform the TRACKING test of Step E. For acceptable long-term performance, the CRT should maintain tracking with the LIFE test button held down.
3. Release the LIFE and TRACKING buttons.
4. If life expectancy is poor, proceed to CLEAN•BALANCE.

NOTES

Other clues for judging life expectancy are obtained by observing the "warm-up" and "cool-off" behavior of the cathode. To make these observations in the TEST position, press any RESTORE pushbutton (18, 19, 20). This interrupts the heater circuit and makes it possible to observe the rate at which the emission rises and falls as the cathode heats up and cools down.

Since the emission from all three guns of a color CRT is displayed simultaneously, significant differences between cathodes are easily observable. If, for instance, during warm-up, one gun reaches full emission much slower than the other two, it is an indication that there may be very little good material left on that cathode or that its heater has been dislodged away from the cathode causing lower than normal cathode temperature. In either instance, it is a further indication that short life may be expected from that gun. A good tube will reach full emission levels and *will track* within two minutes.

Similarly, the "cool-off" characteristic can provide another clue for judging life expectancy. Observe the time it takes for emission from each gun to fall after the heater voltage is interrupted. If, for instance, two guns maintain full emission for 7 to 10 seconds, and the third gun falls rapidly after 3 or 4 seconds, short life can be expected from that gun.

G. FOCUS ELECTRODE CONTINUITY TEST:

With the FUNCTION Switch in the TEST position, depress the FOCUS pushbutton (15). Observe the FOCUS-OK lamp (15). If the FOCUS-OK lamp glows or flickers, the focus electrode continuity to the tube base pin is good.

NOTE

It is also possible to check for an open interconnection in color CRT's, with individual focus electrodes that are internally connected by welded straps. To do this, push the FOCUS test button and observe the 3 emission readings on the meters.

If all 3 meter readings drop approximately the same amount, the inter-electrode continuity is good.

If one or two meter readings drop slightly while the other drops to near zero, there is no continuity to the focus electrode of the *low reading gun*, even though the FOCUS-OK lamp glows.

If the tube tests bad for focus continuity, a decision to replace the tube should be based on actual performance in the TV set. If the focus is not objectionable to the customer, the CRT need not be replaced.

RESTORING THE PICTURE TUBE

The Model 467 employs three restoring functions: REMOVE SHORTS, CLEAN•BALANCE, and REJUVENATE. All three are available in the RESTORE position of the function switch.

LEAKAGE AND SHORTS: Excessive leakage or a short between the control grid and cathode will show up in the LEAKAGE test that is automatically performed during SET-UP. A low resistance short (less than 20k ohms) can be removed by the REMOVE SHORTS procedure. High resistance leakage is most successfully removed by the CLEAN•BALANCE procedure. If grid-to-cathode leakage was indicated in the LEAKAGE test during SET-UP, use the following procedure.

A. REMOVE SHORTS:

1. Set the FUNCTION SWITCH to the RESTORE position.
2. Observe the G1-K lamp (16). If it is not glowing, a high resistance leakage is indicated; use the CLEAN•BALANCE procedure.
3. If the G1-K lamp glows, push the REMOVE SHORTS button (16) and release. If the short has been successfully removed, the lamp will not glow.
4. If the lamp continues to glow, repeat Step 3 several times. Wait 5 to 10 seconds between operations. If the short has not been successfully removed, reduce the heater voltage by turning the HTR RANGE (3) switch to the lowest range. If the G1-K shorts lamp goes out as the cathode cools, it indicates that the short may be due to mechanical expansion of the cathode. Such shorts usually cannot be removed.
5. After the short is removed, resume the testing procedure.

NOTE

One or more LEAKAGE lamps may glow temporarily if the FUNCTION switch remains in RESTORE position for longer than 15 seconds. Also, if returning to SET-UP to re-check leakage, wait at least one minute to get a true leakage indication.

CLEANING, BALANCING AND REJUVENATING

Cleaning and balancing is a low energy restoring operation. It can be used safely on all tubes to eliminate surface contamination causing high resistance leakage or for further improving the emission of a fairly good cathode to restore tracking or increase life expectancy. Rejuvenation is a higher energy procedure for restoring cathodes when the emission is below usable levels.

High level rejuvenation of one gun can occasionally reduce the previous emission reading of another gun, particularly if that gun had just been rejuvenated. Therefore, after rejuvenation, it is often desirable to "touch-up" by cleaning and balancing one or more of the guns in order to achieve good tracking.

B. CLEAN•BALANCE:

1. Set the FUNCTION Switch to the RESTORE position and the REJUVENATE/CLEAN•BALANCE Switch (17) to CLEAN•BALANCE. Wait 20 to 30 seconds. Observe the CRT heater for increased brightness from the higher heater voltage.
2. Push and hold the RESTORE button (18), (19), or (20) for the gun to be cleaned or balanced. The meter should rise immediately to a value near midscale. After several seconds or more, depending upon the condition of the cathode, the pointer will begin to fall. It usually will fall smoothly to some low value.
3. Release the RESTORE button when the pointer reaches 0.2. If the pointer drops erratically and then "hangs up" at a reading greater than 0.2, wait several seconds and then release the RESTORE button. Also, observe the G1-K SHORT lamp. If it is glowing, remove the short before proceeding further.
4. Return the FUNCTION Switch (1) immediately to SET-UP (if LEAKAGE was being removed), or to TEST (if balancing or "touch up" was being done). Resume testing.
5. If the CLEAN•BALANCE procedure was not successful and the condition of the CRT is still unsatisfactory, use the REJUVENATE procedure.

C. REJUVENATE:

1. Set the FUNCTION Switch (1) to the RESTORE position. Set the REJUVENATE/CLEAN•BALANCE Switch (17) to REJUVENATE. Wait 20 to 30 seconds.
2. Push and hold the RESTORE BUTTON (18), (19), or (20) for the gun to be rejuvenated. The pointer immediately will rise to about $\frac{3}{4}$ scale and the

RESTORE ballast (current limiting) lamp (21) will glow brightly. After several seconds, the pointer will begin to fall. Often the pointer will fall erratically or hesitate near midscale and then rise slightly before continuing to fall. This behavior is usually accompanied by observable sparking and sputtering action between the grid and cathode.

3. Release the RESTORE button when the pointer reaches 0.4 or just as it crosses into the red area of the meter. If the emission does not fall to 0.4 after several seconds, release the RESTORE button immediately. Observe the G1-K SHORTS lamp (16) to see if a short was created by the rejuvenation process. If a short exists, use the REMOVE SHORTS procedure.
4. Return to TEST. Allow time for readings to stabilize. A rapid judgment of relative improvement can now be made. For greater accuracy, repeat SET-CUTOFF.
5. Repeat LIFE and TRACKING tests. If slight further improvement is needed, or if rejuvenation caused lower emission from one of the other guns, use the CLEAN•BALANCE procedure.
6. If the CLEAN•BALANCE procedure after rejuvenation does not give the necessary improvement, repeat REJUVENATE. Most cathodes will achieve 90% or more of the possible improvement in a single operation. Some will require two or three cycles of rejuvenation for maximum improvement. Further rejuvenation generally causes lower emission and shorter life. The fewer rejuvenation cycles that are used to achieve satisfactory emission, the greater will be the life expectancy.

NOTES

If the meter pointer does not rise when the RESTORE button is pushed, it indicates that successful rejuvenation is probably not possible. If the reason for lack of emission is an extremely inactive (contaminated) cathode, it is sometimes possible to start the rejuvenation process by applying even higher heater voltage than normally used for rejuvenation. To try this, go back to SET-UP and increase the heater voltage approximately 25% above the *normal* setting (8.0V for 6.3V tubes). Then return to RESTORE and attempt rejuvenation. Since the tube is not useful anyway, the risk is small. The greatest danger is that excessive heater voltage will expand the cathode so far that a short to G1 will be created. Also, of course, the heater itself could be burned open by the higher voltage, although this occurs less frequently than a short.

If all three guns show initial low emission (BAD), rejuvenation of one gun will often result in some improvement of the other two guns. (This is caused by the elevated heater voltage which is a mild form of rejuvenation in itself.) These guns should also be rejuvenated, however, even though the emission may have been improved enough so they read in the GOOD region.

HOW THE MODEL 467 WORKS

EMISSION TEST

The multiplex test method (Patent Applied For) employed in the DYNASCAN Model 467 tests the three guns in a rapid-fire sequence, on a 1/3 duty cycle time-share basis (Fig. 1). Each gun is pulsed 20 times per second and the peak current of each gun is continuously indicated on its individual meter. The current indicated is "true" beam current — that is, only the current passing through the G1 aperture. A GOOD emission indication on the meter, therefore, assures that (given the high voltage), the gun is capable of producing adequate highlight brightness on the face of the picture tube.

The G2 voltage is supplied by a digitally programmed regulator so that it can be automatically adjusted to the G2 cutoff value of each gun, during the gun's test interval. This is why the test set-up and procedure is the same for even those tubes that have a common connection to all three G2 elements.

TRACKING TEST

The multiplex system greatly simplifies the tracking test (Fig. 2). The 1½ to 1 limit for emission between the highest and lowest guns is checked by showing this ratio on the meter scale as a yellow wedge extending upward from the GOOD-BAD limit line. The TRACKING control changes all three meter readings by the same *percentage* so that if all three pointers can be placed in the yellow area, you know the guns are tracking. Changing the three meter readings by *exactly the same percentage* is accomplished electronically by changing the *duration* of each test interval exactly the same amount. Thus, if each gun is on for only 1/6 instead of 1/3 of the time, each meter reads 50% of its former value.

LEAKAGE TEST

The multiplex system simplifies the leakage test (Fig. 3). Like the limit used to make a GOOD-BAD judgement of emission, a leakage limit somewhat higher than the manufacturer's limit for a new tube is used — a limit at which you might expect trouble to begin showing up in a typical TV set. Fortunately, such a leakage limit is just high enough to cause a neon lamp to glow. By using a group of 5 lamps (one for each cathode, one for the heater, and one for G1), and multiplexing the test circuit, we can observe leakage between any two cathodes or from any cathode to the heater or G1. (Both lamps will glow, showing which two elements are involved.) This test is made automatically with the function switch in the SET-UP position and requires no operator adjustment. It will detect almost any leakage problems that do occur, including those troublesome cathode-to-cathode leaks.

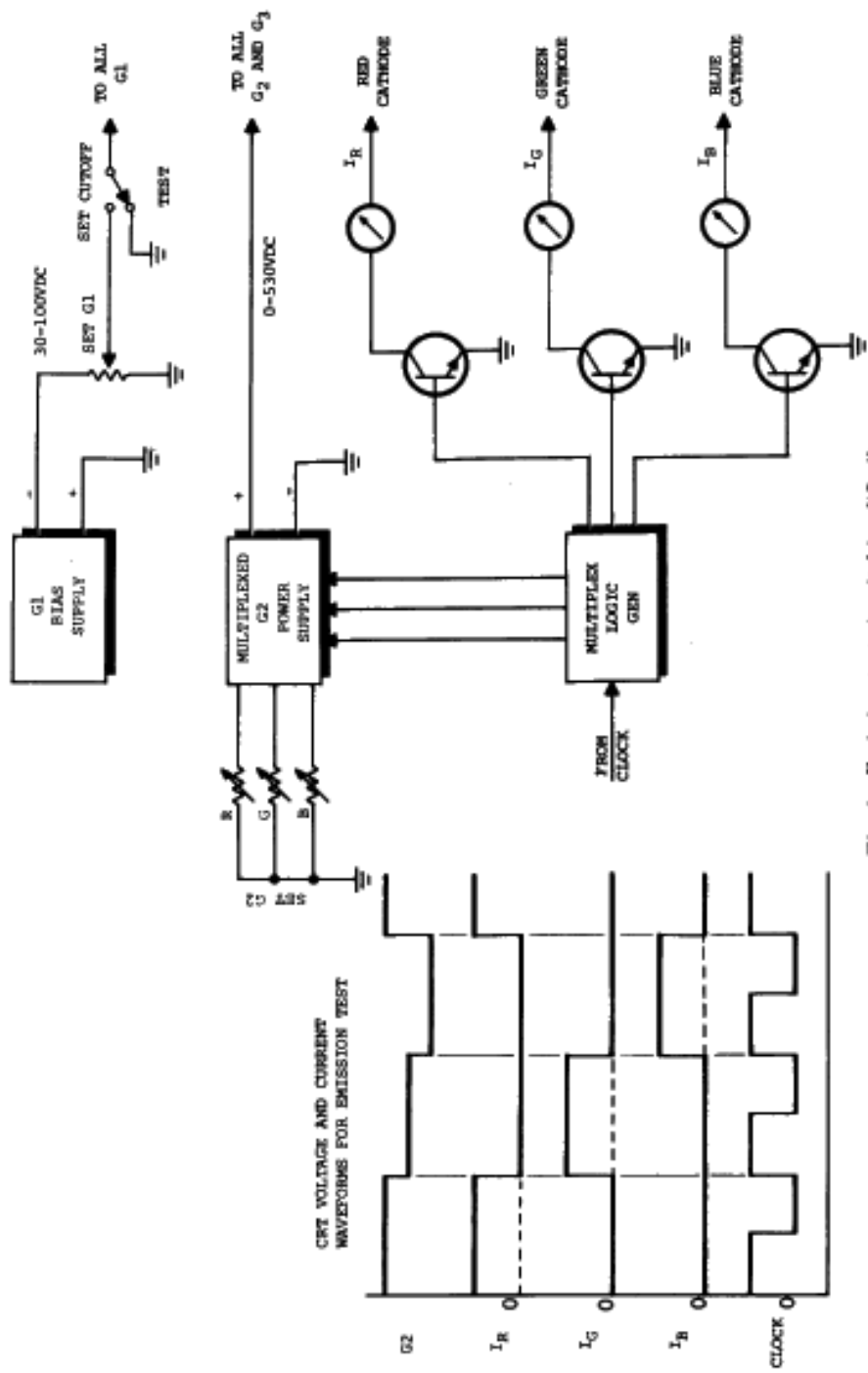

Fig. 1. Emission test circuit (simplified).

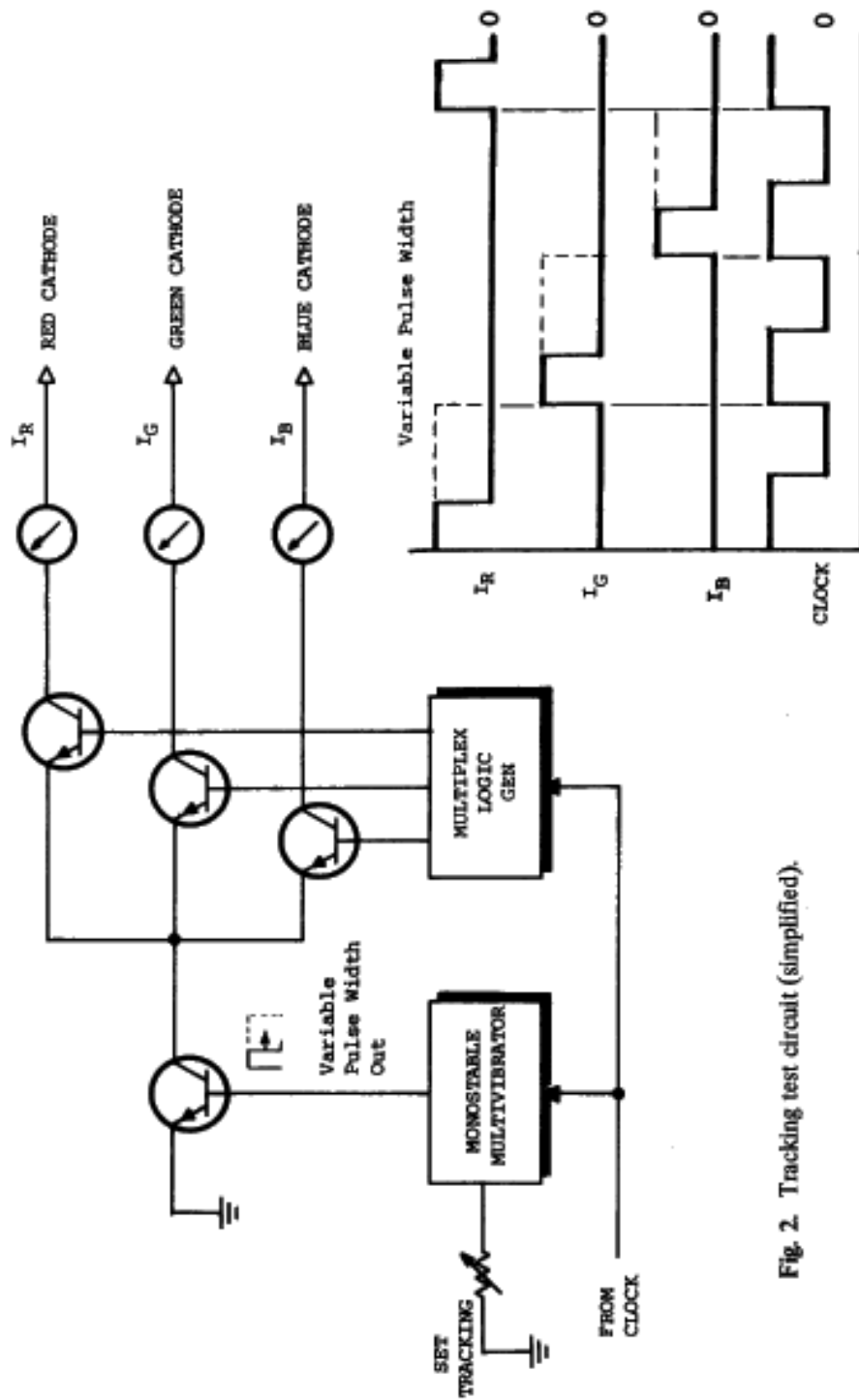

Fig. 2. Tracking test circuit (simplified).

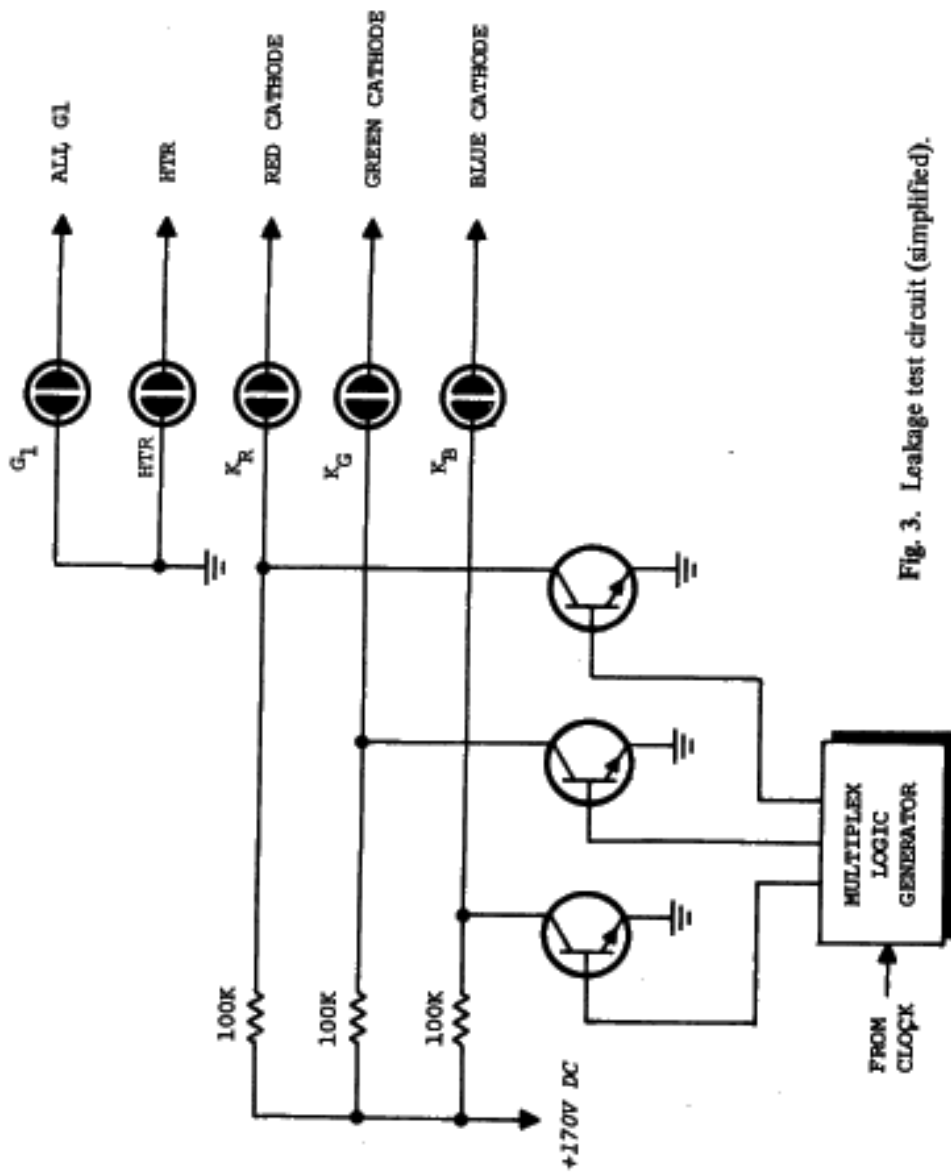

Fig. 3. Leakage test circuit (simplified).

LIFE TEST

It can generally be assumed that picture tubes showing high emission levels (1.0mA and over) will continue to perform acceptably for long periods of time, and that the performance will not be degraded appreciably by abnormal supply voltage conditions such as low heater voltage. However, when the picture tube shows emission levels that are relatively low (below 1mA) even though they may be in the GOOD region, it is highly desirable to evaluate performance both from the standpoint of future life expectancy and behavior at reduced heater voltage. This is particularly true with regard to tracking performance, and has become an increasingly important test in these energy-crisis times of "brown-outs" with reduced line voltage levels to homes.

One of the best means of estimating the remaining useful life of a picture tube is to observe the decrease in emission with reduced heater voltage. If the performance, (either emission or tracking) becomes unsatisfactory with a 15% reduction in heater voltage, you can be assured that the future useful life of the tube is rather limited.

To facilitate this analysis in the Model 467, a LIFE test pushbutton is provided which automatically reduces the heater voltage by 15% from *any* normal value previously set on the heater voltage meter. Simply depressing the LIFE test pushbutton permits very rapid evaluation of both the remaining life expectancy of a picture tube and its performance at reduced heater voltage.

Other clues for judging life expectancy are the "warm-up" and "cool-off" behavior of the cathode. These tests are easily performed by applying or removing heater voltage while observing emission. Therefore, those sections of the RESTORE pushbutton switches that interrupt the heater supply are arranged to be operative in the TEST position.

FOCUS TEST

When the FOCUS TEST pushbutton is pressed, a large resistance is connected in series with the G2 electrodes (Fig. 4). The focus electrode(s) however, are connected directly to the full G2 supply voltage through a sensitive neon lamp. The large resistor reduces the G2 electrode voltage thus allowing more current to be picked up by the focus electrode which is indicated by the neon lamp glow.

There will always be some drop in emission when the focus test button is pressed. Some gun structures will exhibit a large drop and others only a very small drop. Those guns showing a large drop have a common focus electrode that is virtually a one piece mechanical structure so that an open connection to a single focus electrode is practically impossible. However, some gun structures exhibiting a small drop may employ separate focus electrodes which are interconnected by a welded metal strap, and an open connection may occur to only one or two focus electrodes. Even if the base pin has continuity to only one focus electrode, the test will still show FOCUS-OK. However, an open focus interconnection to one gun will show a large drop in emission instead of a small drop, thus making it possible to detect the open interconnection.

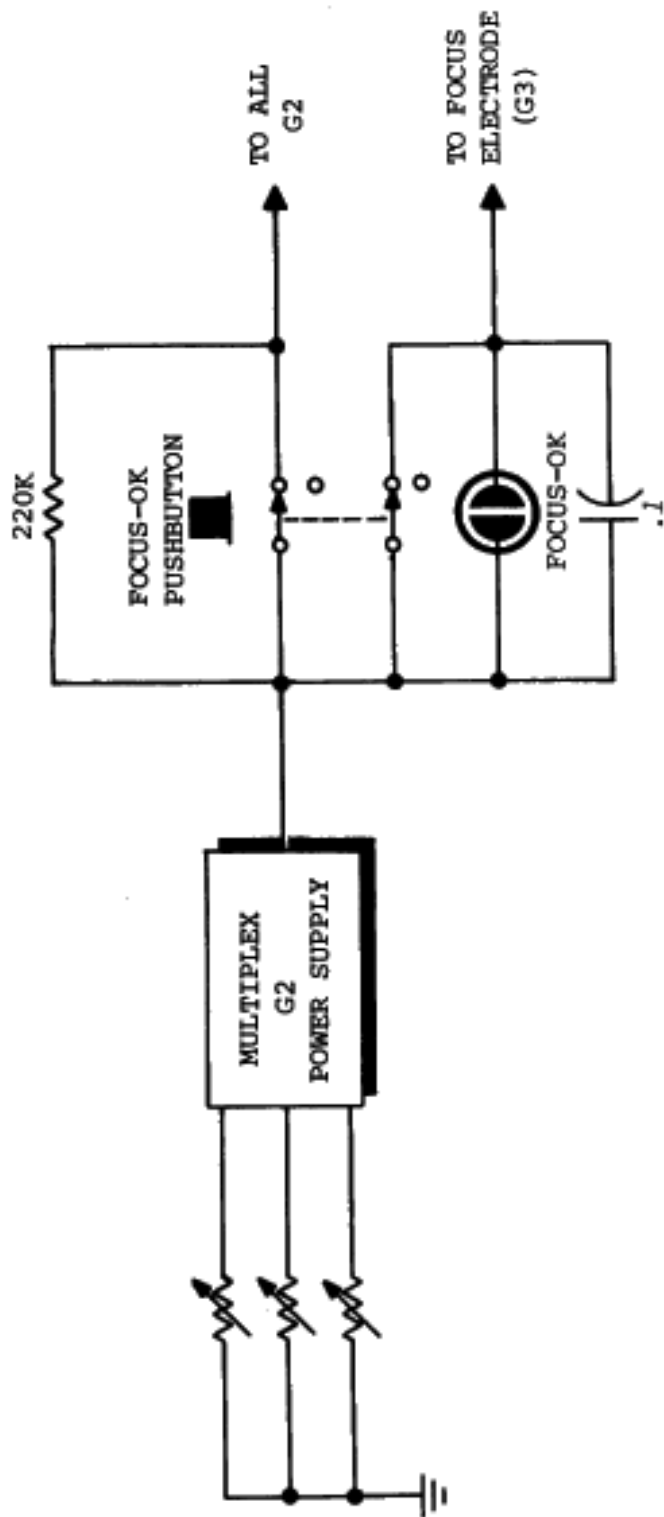

Fig. 4. Focus continuity test circuit (simplified).

SHORTS REMOVAL

Picture tube guns are constructed with extremely small spacing between the cathode and the G1 (control) electrode. This close spacing, together with the possibility of the cathode coating material becoming loose and bridging the gap between the cathode and the control grid often results in a fairly low resistance short between these elements. The presence of such a short will be immediately detected in going through the normal test sequence with the Model 467, because the leakage indicator lamps will glow brightly showing which cathode is shorted to G1. Upon moving the function switch to the RESTORE position another neon lamp (G1-K Short) will glow brightly indicating that a *low resistance* short does exist (Fig. 5).

Such a short can usually be eliminated by means of a high energy discharge from a capacitor. Pressing the REMOVE SHORTS button of the Model 467 places a capacitor (previously charged to a high voltage) across the short (Fig. 6). When the short has been successfully burned out, the G1-K SHORT indicating lamp will not glow.

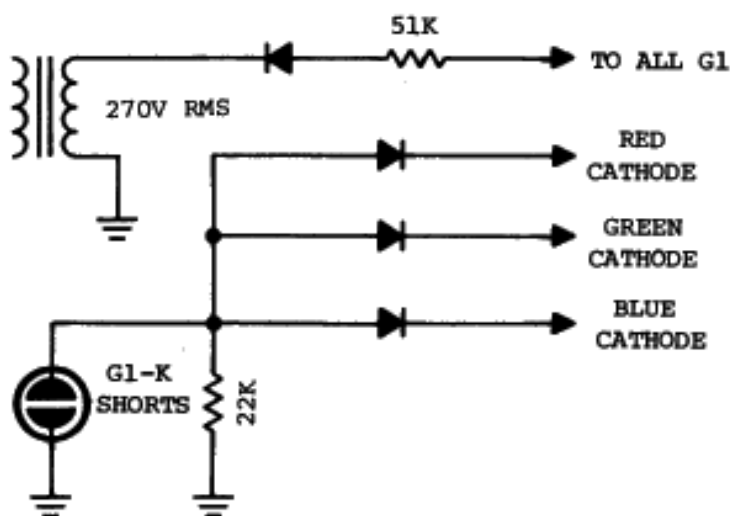

Fig. 5. G1-K short indicator lamp (simplified).

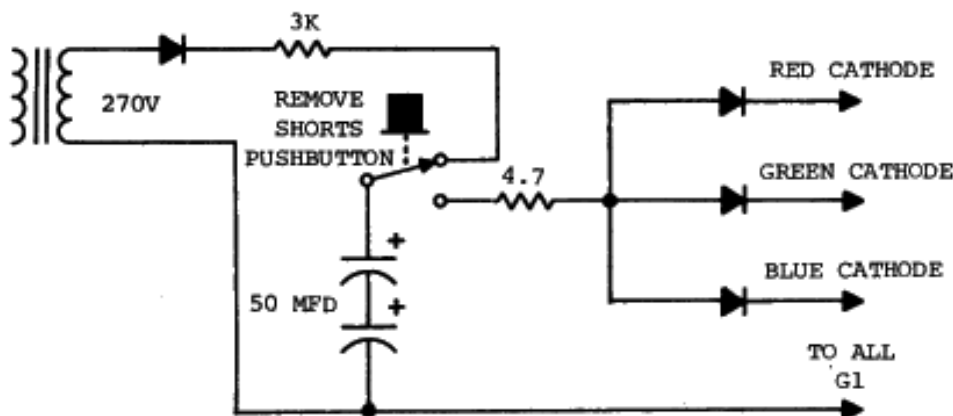

Fig. 6. G1-K short removal circuit (simplified).

CATHODE RESTORING

The most effective technique for cathode rejuvenation involves elevating the heater voltage and simultaneously applying a high positive voltage between G1 and cathode, thus causing a much greater than normal cathode current to flow. Unfortunately, unless this process is very carefully controlled, the cathode can easily be damaged and instead of improving performance, the emission capability of the cathode is lowered or destroyed.

This problem is avoided in the Model 467 by *pre-heating* the cathode, and then initiating the rejuvenation cycle by means of a pushbutton which *applies* the high rejuvenation voltage to the control electrode, and simultaneously *removes* the heater voltage (Fig. 7). This permits a high rejuvenation current to begin flowing immediately as the rejuvenation button is pressed, but permits the current to flow only as long as the cathode retains sufficient heat to maintain the temperature required for emission. The rejuvenation cycle is therefore automatically terminated when the cathode cools below the point at which emission can be sustained. This time interval will depend upon both the condition of the cathode emitting surface, and the thermal characteristic of the cathode structure. The larger, more rugged cathodes will result in a longer rejuvenation cycle and, of course, they are the ones that need and can withstand the longer time interval with less danger of being damaged. Therefore, the cathode structure itself serves as the automatic timing element that adjusts the timing interval according to its own needs. This technique, which prevents *simultaneous* application of heater and rejuvenate voltage is an exclusive (Patent Applied For) feature of the Model 467's cathode restoring system.

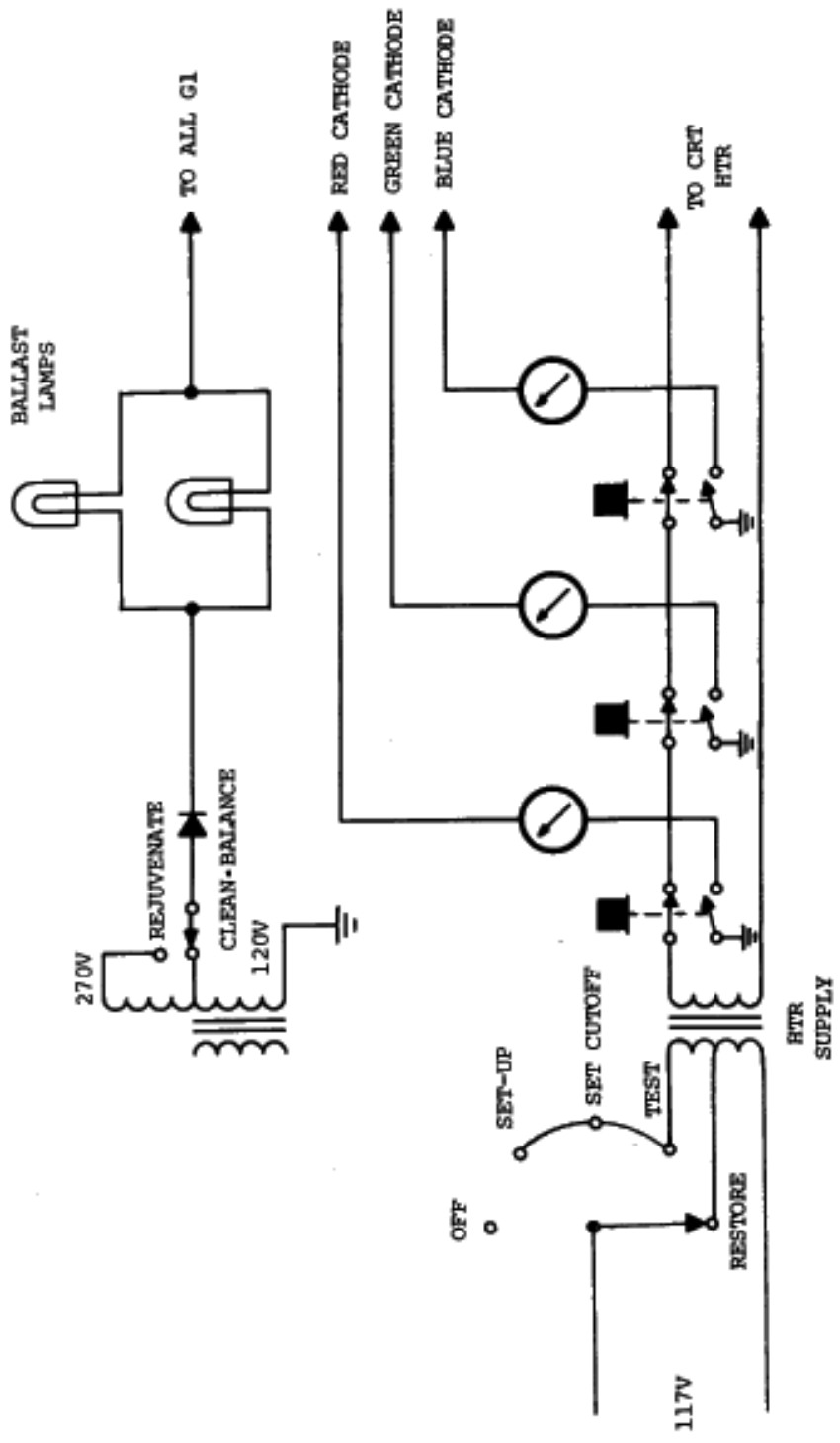

Fig. 7. Rejuvenate/Clean-Balance circuit (Simplified).

The same procedure can be used at different energy levels by changing the value of the applied voltage. Higher voltage is required for rejuvenation to start the process when the cathode has become an extremely poor emitter. Lower energy should be used to minimize possible damage to the cathode for cleaning high resistance contamination between grid and cathode, and increasing the emission of a good cathode to improve tracking. Therefore, it is desirable to use the lower energy procedure provided in the CLEAN•BALANCE function for those operations.

Describing the emission test earlier, it was pointed out that the Model 467 tests the emission and tracking performance of a picture tube by indicating the true beam current – that is, only the current passing through the G1 aperture which is useful for producing light output from the face of the picture tube. This beam current is derived from a very small area of the cathode located directly beneath the small aperture hole in the G1 control electrode. Obviously, for the rejuvenation process to be successful it is from this region that emission must be restored. During the rejuvenation process a very large current flows from the entire cathode surface to the highly positive G1 electrode. Although the amount of current flow from the cathode to G1 is an indicator of the overall condition of the cathode, G1 current itself is of no use in evaluating the ability of the cathode to supply true beam current. Therefore, in order to know the quality of the tube after the restoring process has been completed, it is absolutely necessary to make a true beam current emission test.

FIELD CALIBRATION

HTR VOLTS:

1. Connect suitable AC voltmeter ($\pm 3\%$ or better) to pins 1 and 14 of Adapter No. 3. Connect Adapter to test cord.
2. Set AC voltmeter range switch to 10V.
3. Plug in 467 and set function switch to SET-UP.
4. Set HTR Range switch to 4 – 7 volts.
5. Adjust SET HTR control to read exactly 6.3V on external voltmeter.
6. Adjust R16 (located on printed circuit board) so that HTR volt meter (Red B&W) indicates exactly 6.3V.

SET-UP CHARTS

An up-to-date test chart is included with your Model 467. In order to keep your set-up chart up-to-date, it is recommended that you subscribe to the B&K Chart mailing service. These mailings will occur in May and November of each year and will include all the tubes presently listed on your chart plus all new types of CRT's that have come out since the last mailing.

If you wish to take advantage of this service, remit cash, check, or money order (no COD's please) to:

B&K Division of Dynascan Corporation
2815 W. Irving Park Road
Chicago, Illinois 60618

and you will be placed on the subscription list.

WARRANTY SERVICE INSTRUCTIONS

1. Refer to the **MAINTENANCE** section of your B & K-Precision instruction manual for adjustments that may be applicable.
2. Defective parts removed from units which are within the One Year Limited Warranty period should be sent **PREPAID** to the Service Department listed below. Be sure to state the model and serial number of the unit from which the parts were removed and date the unit was purchased. These parts will be exchanged at no charge, under the terms of the Warranty.
3. If the above-mentioned procedures do not correct the problem you are experiencing with your unit, pack it securely (preferably in the original carton or double-packed). Enclose a letter describing the problem and include your name and address. Deliver to, or ship **PREPAID** (UPS preferred) to the nearest B & K-Precision authorized service agency (see list enclosed with unit).

If your list of authorized B & K-Precision service agencies has been misplaced, contact your local distributor for the name of your nearest service agency, or write to:

Service Department

B & K-Precision Product Group
DYNASCAN CORPORATION
2815 West Irving Park Road
Chicago, Illinois 60618

LIMITED ONE-YEAR WARRANTY

DYNASCAN CORPORATION warrants to the original purchaser that its B & K-PRECISION product, and the component parts thereof, will be free from defects in workmanship and materials for a period of one year from the date of purchase.

DYNASCAN will, without charge, repair or replace, at its option, defective product or component parts upon delivery to an authorized B & K-PRECISION service contractor or the factory service department, accompanied by proof of the date of purchase in the form of a sales receipt.

To obtain warranty coverage, this product must be registered by completing and mailing the enclosed warranty registration card to DYNASCAN, B & K-PRECISION, P.O. Box 35080, Chicago, Illinois 60635 within five (5) days from the date of purchase.

Exclusions: This warranty does not apply in the event of misuse or abuse of the product or as a result of unauthorized alterations or repairs. It is void if the serial number is altered, defaced or removed.

DYNASCAN shall not be liable for any consequential damages, including without limitation damages resulting from loss of use. Some states do not allow limitation of incidental or consequential damages, so the above limitation or exclusion may not apply to you.

This warranty gives you specific rights and you may also have other rights which vary from state to state.

For your convenience we suggest you contact your B & K-PRECISION distributor, who may be authorized to make repairs or can refer you to the nearest service contractor. If warranty service cannot be obtained locally, please send the unit to B & K-PRECISION Service, 2815 West Irving Park Road, Chicago, Illinois 60618, properly packaged to avoid damage in shipment.



DYNASCAN CORPORATION

6460 West Cortland Street

Chicago, Illinois 60635

480-156-9-001C

B & K-PRECISION MODEL 467 PARTS LIST

488-141-9-002F

SCHEMATIC SYMBOL	DESCRIPTION	B & K-PRECISION PART NO.
------------------	-------------	--------------------------

ELECTROLYTIC CAPACITORS

C1, 2, 3	220 μ f @ 100V DC	022-109-9-001
C11, 12	50 μ f @ 450V DC	021-056-9-001
C13, 14	1000 μ f @ 16V DC	022-084-9-001
C19, 20	10 μ f @ 250V DC	021-040-9-001

DIODES & TRANSISTORS

D1,2,3, 4,5,6,7, 8,9,10, 11,12,13, 14,15, 17,18,19, 26,27,28, 38	} Rectifier, 600 PIV @ 1 Amp	151-018-9-001
D20,21,22, 23,24,25, 29	} Silicon Diode, 1N4148	151-038-9-001
D30	Germanium Diode, 1N67(A)	150-008-9-001
D31,36,37	Zener Diode, 56V \pm 10%, 1 Watt	152-056-9-001
D32	Zener Diode, 24V \pm 5%, 1 Watt	152-014-9-001
D33	Zener Diode, 5.1V \pm 5%, 1 Watt	152-030-9-001
D34,35	Zener Diode, 91V \pm 10%, 1 Watt	152-058-9-001
Q1,2,3,4, 5,6,7	} Silicon Transistor, 2N5550	176-033-9-001
Q8,9,10	Silicon Transistor, PN3643	176-052-9-001
IC1	7473 Dual J-K Flip-Flop	307-010-9-001
IC2	7400 Quad Two Input NAND Gate	307-015-9-001

RESISTORS & CONTROLS

R7,8,9	2.4 Ω \pm 5%, 1/4W, Carbon Resistor	002-104-8-249
R10,11,12	316 Ω \pm 1%, 1/2W, Carbon Resistor	002-017-9-001
R16	10K, \pm 20%, Linear Trimpot	008-058-9-001
R19	499K, \pm 1%, 1/2W, Carbon Film Resistor	002-032-9-001
R20	50K Ω , \pm 30%, Linear Trimpot	008-093-9-001
R23	250K, \pm 30%, Linear Trimpot	008-071-9-001
R22,33, 49,50,51	} 50K, \pm 10%, Linear, 1/2W Carbon Pot	008-135-9-001
R39	4.7 Ω , 10%, 1/2W, W.W. Resistor	006-102-9-479
R43	30K, 10W, W.W. Glass Resistor	003-010-6-303
R67	3 Ω \pm 10%, Linear, 12W, W.W. Pot	009-029-9-001

SWITCHES

S1	5-position Rotary Switch (Function)	083-165-9-001
S2	6-position Rotary Switch (Htr. Range)	083-091-9-001
S3,4,5,9	4-Station Pushbutton Assembly	088-020-9-001
S6,7,8	Pushbutton Switch, DPDT Momentary	088-026-9-001
S10	SPDT Slide Switch	084-001-9-001
S11	DPDT Slide Switch	084-001-9-003

COMPOSITE
499-069-9-001G

SCHEMATIC SYMBOL	DESCRIPTION	B & K-PRECISION PART NO.
---------------------	-------------	-----------------------------

MISCELLANEOUS

F1	Fuse, 3/10A, 250V, 3 AG Slo-Blo	190-004-9-001
F2	Fuse, 1/4A, 250V, 3AG Slo-Blo	190-251-3-102
F2	Fuse, 3/8A, 250V, 3AG Slo-Blo (CSA Units)	190-251-3-308
11, 2	Bulb, 230V, 10W	400-034-9-001
N1,2,3, 4,5,6, 7,8, }	Neon Bulb, NE-2 with 7" Leads	401-016-9-001
T1	Power Transformer, 117 Volts	065-098-9-001
T1	Power Transformer, 240 Volts	065-098-9-002
T2	Filament Transformer	062-004-9-001
M1	Meter, Heater Volts	320-059-9-001
M2	Meter, G1 Volts	320-060-9-001
M3	Meter, Line Volts	320-058-9-001
	Line Cord	420-001-9-009
V1	12BH7A Tube	236-120-2-087
	Case Assembly	523-137-9-001
	Knob, Function	751-005-9-008
	Knob, Small	751-112-9-001
	Knob, Heater Range	751-115-9-001
	Knob, Pushbutton, Black	384-016-9-006
	Lens Cap, Red	750-003-9-001
	Lens Cap, Clear	750-003-9-002
	Tube Chart	497-018-0-000
	Instruction Manual	480-156-9-001
	Guarantee, CRT, 20 per pad	483-174-9-001
	Output Cable Assembly	
	Rubber Foot	381-002-9-001
	Lamp Socket	752-007-9-001
	Vinyl Divider flap	758-021-9-001
	Hinge Wire (Flap)	763-027-9-001
	Adapter Storage Assembly	523-103-9-001

NOTE: Standard value resistors and capacitors are not listed. Values may be obtained from schematic diagram. Minimum charge \$5.00 per invoice. Orders will be shipped C.O.D. unless previous open account arrangements have been made or remittance accompanies order. Advance remittance must cover postage or express charges. Specify serial number when ordering replacement parts.

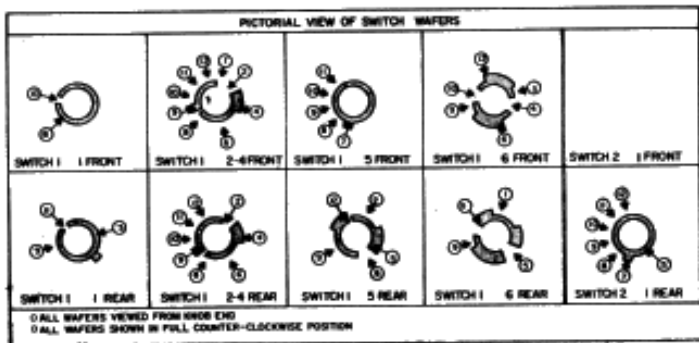
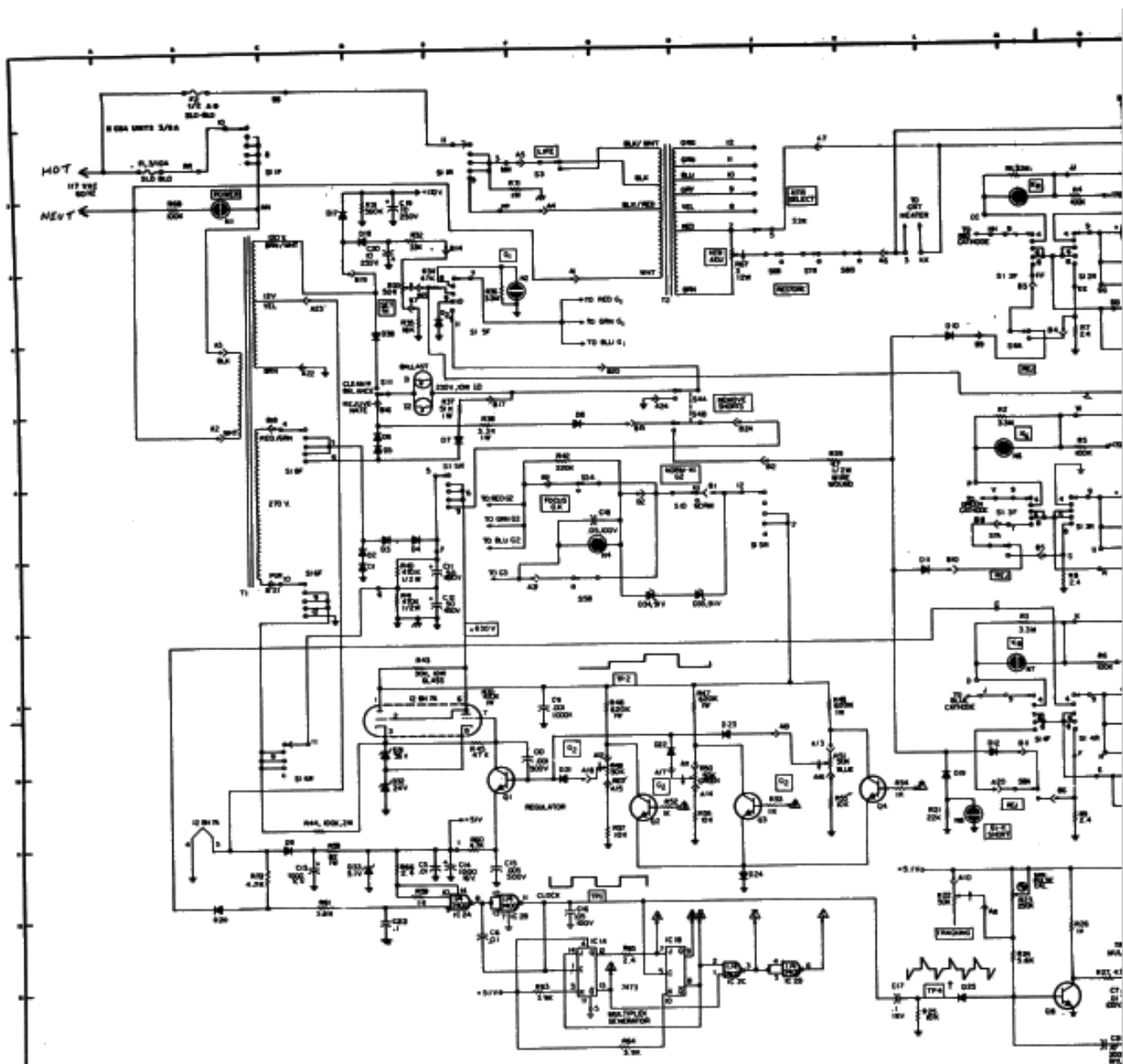

NOTE:

- 1 ALL RELAYS
- 2 ALL FN RE
- 3 ALL CAPAC
- 4 ARROWS ON TRANSISTOR
- 5 THIS SCHEM
- 6 ALL CARRY
- 7 TEST
- 8 CIRCUIT
- 9 WAFERS WITH ON

SWITCH LEGEND (SI)

POSITION	FUNCTION
1	POWER OFF
2	SET UP
3	SET CUTOFF
4	TEST
5	RESTORE

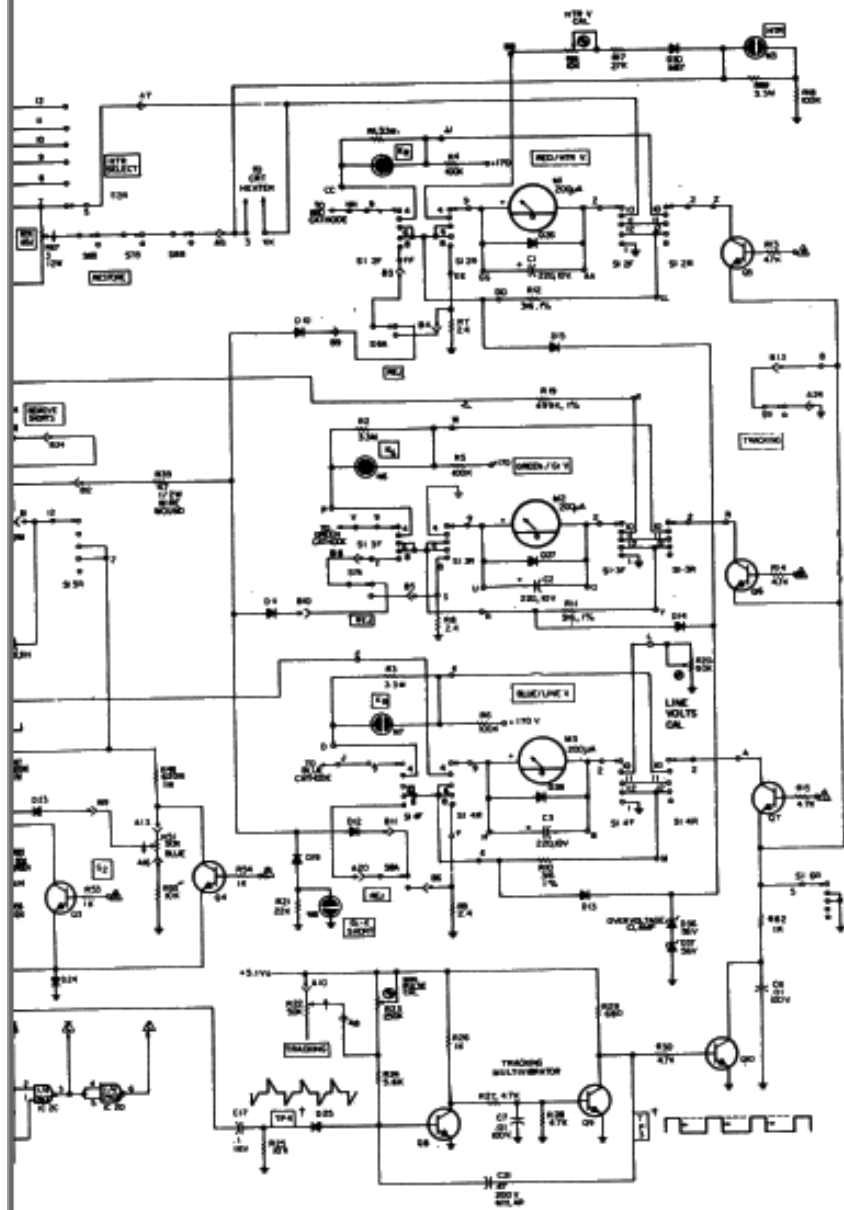

CAUTION: THIS UNIT CONTAINS HIGH VOLTAGE SUPPLIES. BE CAUTIOUS WHEN SERVICING.

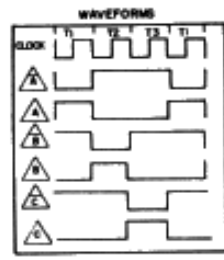

OUTPUT CABLE

FUNCTION	WIRE COLOR	PIN NO.
HTR	BLK	1
HTR	WH	2
G1 RED	GRY	3
G1 GRN	TRN	4
G1 BLU	PUR	5
K RED	RED	6
K GRN	GRN	7
K BLU	BLU	8
G2 RED	ORG	9
G2 GRN	YEL	10
G2 BLU	PINK	11
G3 / G4	WHT	12

SWITCH LEGEND (S1)

POSITION	FUNCTION
1	POWER OFF
2	SET UP
3	SET OUTPUT
4	TEST
5	RESTORE

NOTE:

- ALL RESISTORS ARE 5%, 1/4W UNLESS OTHERWISE SPECIFIED.
- ALL 1% RESISTORS ARE 1/2W UNLESS OTHERWISE SPECIFIED.
- ALL CAPACITORS SHOWN IN MICROFARADS.
- ARROWS ON POT WIPERS INDICATE CLOCKWISE ROTATION.
- TRANSISTORS 1 THRU 7 ARE 2N5550. TRANSISTORS 8 THRU 10 ARE PN3643.
- THIS SCHEMATIC SUBJECT TO CHANGE WITHOUT NOTICE.
- △ AND □ INDICATE LOGIC SYMBOLS.
- ↓ CREDIT SW. = ON/OFF.
- (↑) MARKS WITH CONTROL SWITCHES.

CIRCUIT SYMBOL LEGEND

LAST NUMBER USED	NOT USED
C22	4
D30	6
J2	
K2	
M3	
N8	
Q10	
R72	
S11	
T2	
T3	